

# Assistive Devices/Home Adaptation

For safety and convenience, you may rely on various tools and equipment after a hip fracture. These can help greatly with walking and day-to-day tasks like using the bathroom and bathing.

## Walking Aids

### *Canes*

- If your right hip was fractured, hold the cane in your left hand, and vice versa. If you are using the cane just to help with balance and stability, hold it in the hand you use less.
- Hold the cane close to your body so you can push straight down on it.
- Talk to your doctor if you feel like you need to put a lot of weight on the cane because your balance is not good, or you have lots of pain or weakness.
- Be sure your cane fits you. Stand in your normal posture with the cane tip on the ground. The handle should be next to the top of your leg, with your elbow slightly bent.
- Move the cane at the same time as the opposite leg. If you are holding the cane in your left hand, move the cane forward when you step with your right foot. Set the cane comfortably ahead of you, so it is even with the foot you're stepping with.
- To go up or down a curb, stand near the edge of the curb and get your balance. If you are going up, step up with your stronger leg. Then bring your other leg and the cane up to meet it. If you are going down, move the cane down first. Step down with your weaker leg first, then bring your stronger leg down to meet it.
- To use your cane on stairs, hold on to the banister and use your cane in the opposite hand. Step with the stronger leg first to go up stairs. Step with the weaker leg first to go down.



## *Walkers*

- A walker with four legs is the most stable walking aid. It's good if you need to keep weight off one leg, your general strength or endurance is down, or your balance is off.
- Be sure your walker fits you. Stand in your normal posture and rest your hands on the walker's hand grips. Your hands should be even with the tops of your legs. Your elbows should be slightly bent.
- Set the walker at arm's length in front of you, with all four legs on the floor. Use the handles for balance as you move your weak or injured leg forward to the middle of the walker.
- To go up or down a curb, stand close to the edge while keeping all four legs of the walker down. When you have your balance, move the walker up or down to the surface. Push straight down on the handles for balance and to take weight off your injured leg. Step up with your stronger leg first. Step down with your weaker leg first.
- To sit, back up until your legs touch the chair. Reach back to feel the seat before you sit. To get up from a chair, push yourself up and grasp the walker's grips.



## *Crutches*

- When you are standing still with your crutches, they should be slightly in front of you. The crutches and your feet should form a triangle.
- Hold the crutches close enough to your body so you can push straight down on them. Do not rest your underarms on the tops of your crutches as you could damage a nerve.
- Be sure your crutches fit. Stand in your normal posture. There should be space for two or three fingers between the top of the crutch and your underarm. When you let your hands hang down, the hand grips should be at your wrists. When you put your hands on the hand grips, your elbows should be slightly bent.

- To walk, set the crutches at arm's length in front of you. Don't lean forward. If you can put weight on a leg, move it forward, almost even with the crutches. Push straight down on the handles as you bring your good leg up, so it is even with the injured leg. Keep all the weight on your hands and not on your underarms.
- If you need to keep all the weight off the injured leg, move your crutches forward. Push down on the hand grips and swing your strong leg forward. When you're stronger and your balance is good, you can take a bigger step.
- At a curb, get your balance. Step up with your stronger leg first. Bring the crutches and your weaker or injured leg up to meet it. To step down, move the crutches down first. Step down with your weaker leg. Bring your stronger leg down to meet it. Push straight down on the crutches for balance and to take weight off your injured leg.
- On stairs, hold the banister with one hand. Put both crutches together in the other hand. If you don't think the banister is sturdy enough, or there's no banister, use the crutches normally. If you are going up, step up with your stronger leg first. Bring the crutches and your weaker or injured leg up to meet it. If you are going down, move the crutches down first. Step down with your weaker leg first. Bring your stronger leg down to meet it.



## Bathroom Aids

### Grab bars

- Grab bars attach to a wall in your tub or shower. They're made of stainless steel, aluminum or plastic. They come in a variety of shapes, sizes and colours.
- Choose a grab bar with a textured, non-slip surface as it offers a better grip when the bar is wet. Wrap your hand around the different sizes to find the one that fits you best.
- Most people need two grab bars. One goes vertically along the faucet wall of the tub. That's what you hold when you turn the water on and off, and step over the side. A second goes horizontally along the back wall, which helps you get up after sitting in the tub.
- Screw grab bars into the wall studs so that they can safely take your weight.

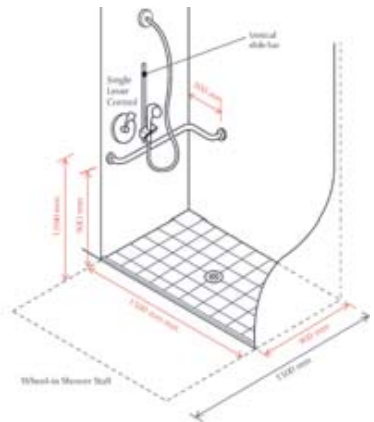
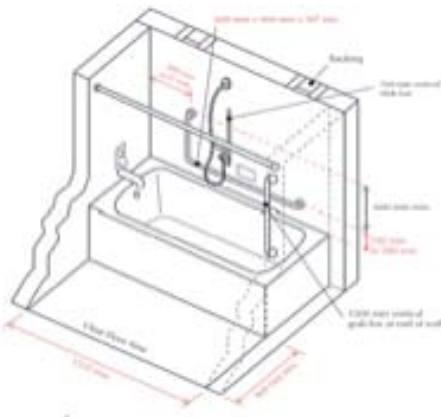
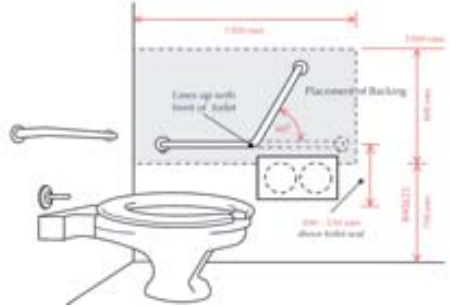

### *Bath or shower seat*

- A bath or shower seat is useful if it's difficult to get down to sit on the bottom of the tub, or if you get weak or dizzy in the shower. These seats are also called chairs, benches or stools.
- Look for a bath seat with adjustable legs and non-skid rubber tips. A seat with a backrest may be more comfortable.
- You'll need a hand-held shower spray. Some seats have a built-in holder for a shower spray.
- A bath seat can generally be used in both bathtubs and shower stalls. Some types may be designed for one or the other.

### *Tub transfer bench*

- A transfer bench can help you get into a shower/tub without climbing over the edge. The bench legs on one side fit over the rim of the tub. The legs on the other side sit inside the tub. The bench allows you to safely slide over the tub rim and lift your legs in.
- Look for a bench with adjustable legs and non-skid rubber tips on the feet.



### *Raised toilet seat*

- A raised toilet seat fits on existing toilets. This adds height, making it easier to sit and stand.



## Other Common Devices

### *Long-handled reacher*

- In a chair or at the edge of your bed, use a reacher to place clothing at the foot of the leg that had the fracture. Slide the clothing over that leg. Pull it up to knee level, then dress your good leg.



### *Sock aid*

- Slip your sock over the sock aid. The heel of the sock should be against the hard plastic side of the sock aid. Place talcum powder inside the sock aid so your foot can slide easier.
- Drop the sock aid to the floor. Slide your foot inside while pulling on the strap. Use your reacher or long-handled shoehorn to adjust or remove your socks.

### *Long-handled shoehorn*

- Putting on a shoe: Use a reacher to hold the top part of your shoe. Slide your foot in while using the shoehorn at the heel. Do not twist your foot while putting on your shoe.
- Taking off a shoe: Use the end of your reacher to push your shoes off.

### *Hip protectors*

- Hip protectors are underwear-type garments with pockets containing hard or soft pads. Basically, they act as shock absorbers. They are good for people who may be vulnerable to injuries if they fall (e.g. because of osteoarthritis), or for those who fear falling.

## Key Things to Remember

- Walking, bathroom and other aids can provide balance and support. They can also decrease the stress on a painful joint or limb and that helps you to be more independent.
- Talk to an occupational therapist about your needs. A health care professional can refer you.
- Who can help:
  - ▶ Medical supply stores;
  - ▶ Home improvement stores;
  - ▶ Select pharmacies;
  - ▶ Red Cross depots;
  - ▶ Service clubs (e.g. Kiwanis, Rotary, Lions Club); and
  - ▶ Health units.
- Veterans may be eligible for help. Visit the Veterans Affairs Canada website for more information at <http://www.veterans.gc.ca>.